



Cameo® List Price Book

Effective October 1, 2025

800-292-8374

www.pinnaclesalesgroup.com

See Our Current
Price Book





Cameo

MAKING A SPLASH

Welcome to Cameo®, where simplicity meets excellence in craftsmanship. Born out of a passion for redefining plumbing experiences, Cameo® is not just a brand; it's a commitment to elevating the standards of functionality and aesthetics in your everyday spaces.

At Cameo®, we believe that plumbing should be as straightforward as it is reliable. Our journey began with a simple idea – to create plumbing solutions that effortlessly blend into your life while standing the test of time. We understand that simplicity is the ultimate sophistication, and our designs reflect a harmonious balance between form and function.



TABLE OF CONTENTS

| | Page |
|---|------|
| Making a Splash | 2 |
| Why Choose Cameo® | 4 |
| Finishing Touches | 6 |
| Products | 8 |
| Diamond Stainless Steel Sinks | 8 |
| Sink Strainers and Disposal Flanges | 11 |
| Soap Dispensers | 12 |
| Kitchen Faucets | 13 |
| Waste Disposers | 14 |
| Cameo® Warranty and Service Information | 15 |
| Pinnacle Sales Group, Inc. Terms & Conditions of Sale | 16 |

Stock items are listed in red; however, inventory levels are subject to change. In order to plan your purchases accordingly we encourage you to check our live inventory by accessing the dealer login on www.pinnaclesalesgroup.com



Why choose Cameo



AFFORDABLE LUXURY

Experience the elegance and sophistication of high-end design without the high price tag. Cameo's products offer luxury that fit any budget.



VERSATILE PRODUCT RANGE

From stainless steel sinks and faucets to waste disposals and accessories, Cameo® provides a complete solution for your kitchen needs, ensuring seamless integration and functionality.



QUALITY CONSTRUCTION

Built with premium materials, including 18-gauge stainless steel sinks, Cameo® products are designed for durability and longevity, providing you with reliable performance and peace of mind.



INNOVATIVE DESIGNS

Our products combine style and practicality, featuring modern designs that enhance the aesthetics and efficiency of your kitchen space.



LIFETIME WARRANTY

Enjoy peace of mind with Cameo's lifetime warranty on all sinks and faucets, ensuring your investment is protected for years to come.



Elevate Your Kitchen Space with Premium Finishing Solutions

Just like a cameo role played by a notable actor, our products make a memorable presence in the kitchen area. With refined design and practical functionality, Cameo® transforms your kitchen into a stage where every cooking experience becomes a noteworthy performance.

Quality is at the heart of everything we do. We meticulously select the finest materials to ensure that every Cameo® product not only meets but exceeds your expectations. From sleek faucets to durable sinks, each component is crafted with precision and durability in mind. Our commitment to using high-quality materials is our promise to you – a promise of reliability, longevity, and a plumbing experience that speaks of true craftsmanship.

Discover the elegance of simplicity, experience the durability of quality –
Welcome to Cameo® Plumbing.

Cameo





Single Bowl Diamond Stainless Steel Sinks

FEATURES

- Premium 304 Stainless Steel Construction
- Commercial Grade, 18 Gauge Stainless Steel
- Suitable for Undermount or Drop In Installation
- Professional Design
- Innovative Design to Effortlessly Direct Water to Strainer
- SilenceTech Sound Dampening Technology
- CleanCurve R10 Radius Corners for Easy Maintenance
- Standard 3 1/2" Drain Opening
- Designed to Prevent Condensation in Outdoor Installations
- Easy Installation
- Lifetime Warranty

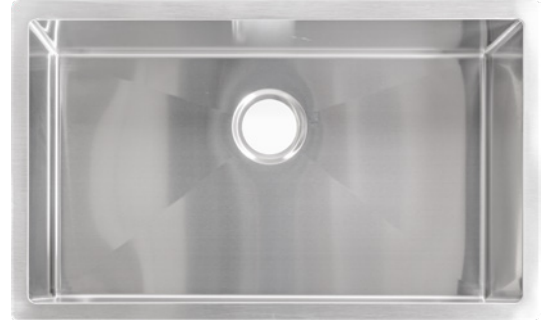

SINGLE BOWL DIAMOND STAINLESS STEEL SINKS



| Item Number | Item Description | Size | External Dimensions (W x L x D) | LIST |
|-------------|--|------|---------------------------------|--------|
| CDS-S16 | 16" Single Bowl Undermount Square Sink | 16 | 16" x 18" x 10" | \$ 449 |
| CDS-S23 | 23" Single Bowl Undermount Square Sink | 23 | 23" x 18" x 10" | \$ 549 |
| CDS-S30 | 30" Single Bowl Undermount Square Sink | 30 | 30" x 18" x 10" | \$ 799 |
| CDS-S32 | 32" Single Bowl Undermount Square Sink | 32 | 32" x 18" x 10" | \$ 899 |

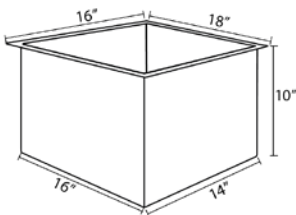

CDS-S16

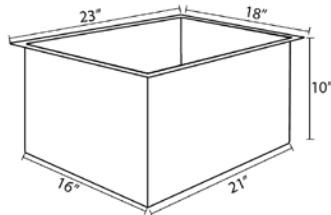

CDS-S23

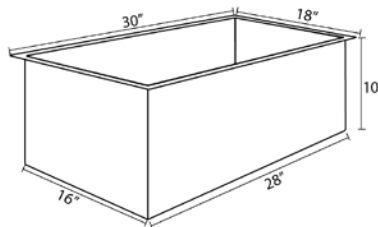

CDS-S30

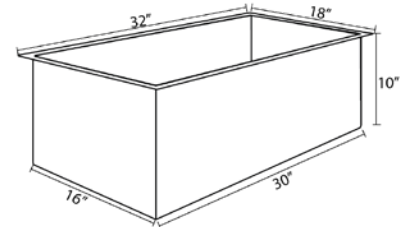

CDS-S32

SINK GRIDS



| Item Number | Item Description | Size | LIST |
|-------------|--------------------------------------|------|--------|
| CDG-S16 | Single Sink Grid for 16" Square Sink | 16 | \$ 99 |
| CDG-S23 | Single Sink Grid for 23" Square Sink | 23 | \$ 99 |
| CDG-S30 | Single Sink Grid for 30" Square Sink | 30 | \$ 109 |
| CDG-S32 | Single Sink Grid for 32" Square Sink | 32 | \$ 109 |



ROLL MAT

| Item Number | Item Description | Size | LIST |
|-------------|------------------------------|------|-------|
| CRM-18 | Flat Roll Mat, 19" x 12 1/4" | 19 | \$ 89 |

Inventory levels are subject to change, check stock via Dealer Login on www.pinnaclesalesgroup.com

Double Bowl Diamond Stainless Steel Sinks

FEATURES

- Premium 304 Stainless Steel Construction
- Commercial Grade, 18 Gauge Stainless Steel
- Suitable for Undermount or Drop In Installation
- Double Bowl Configuration
Available in 70/30 or 50/50 Split
- Professional Design
- Innovative Design to Effortlessly Direct Water to Strainer
- SilenceTech Sound Dampening Technology
- Designed to Prevent Condensation in Outdoor Installations
- CleanCurve R10 Radius Corners for Easy Maintenance
- Standard 3 1/2" Drain Opening
- Easy Installation
- Lifetime Warranty



DOUBLE BOWL DIAMOND STAINLESS STEEL SINKS



| Item Number | Item Description | Size | External Dimensions (W x L x D) | LIST |
|-------------|---------------------------------------|------|---------------------------------|--------|
| CDS-D3273 | 32" Double Bowl 70/30 Undermount Sink | 32 | 32" x 19" x 10" | \$ 999 |
| CDS-D3255 | 32" Double Bowl 50/50 Undermount Sink | 32 | 32" x 18" x 10" | \$ 999 |

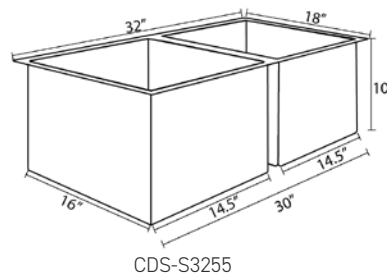
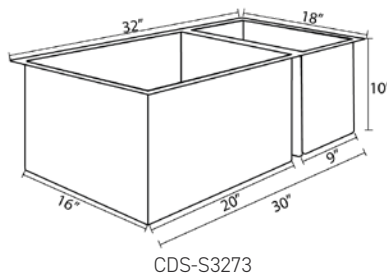

SINK GRIDS

| Item Number | Item Description | Size | LIST |
|-------------|--|------|--------|
| CDG-D3273 | Double Sink Grid for 32" 70/30 Square Sink | 32 | \$ 189 |
| CDG-D3255 | Double Sink Grid for 32" 50/50 Square Sink | 32 | \$ 189 |



ROLL MAT

| Item Number | Item Description | Size | LIST |
|-------------|------------------------------|------|-------|
| CRM-18 | Flat Roll Mat, 19" x 12 1/4" | 19 | \$ 89 |

Inventory levels are subject to change, check stock via Dealer Login on www.pinnaclesalesgroup.com

Diamond Apron Front Stainless Steel Sinks

FEATURES

- Classic Curved Apron Front Design Complements Both Modern and Traditional Kitchen Spaces
- Premium 304 Stainless Steel Construction
- Commercial Grade, 18 Gauge Stainless Steel
- Suitable for Undermount or Drop In Installation
- Professional Design
- Innovative Design to Effortlessly Direct Water to Strainer
- SilenceTech Sound Dampening Technology
- CleanCurve R10 Radius Corners for Easy Maintenance
- Standard 3 1/2" Drain Opening
- Designed to Prevent Condensation in Outdoor Installations
- Easy Installation
- Lifetime Warranty

NEW



DOUBLE BOWL DIAMOND STAINLESS STEEL SINKS

| Item Number | Item Description | Size | External Dimensions (W x L x D) | LIST |
|-------------|--|------|---------------------------------|--------|
| CDS-FA24 | 24" Single Bowl Undermount Front Apron Sink, Stainless Steel | 24" | 24" x 20" x 10" | \$ 899 |
| CDS-FA30 | 30" Single Bowl Undermount Front Apron Sink, Stainless Steel | 30" | 30" x 20" x 10" | \$ 999 |

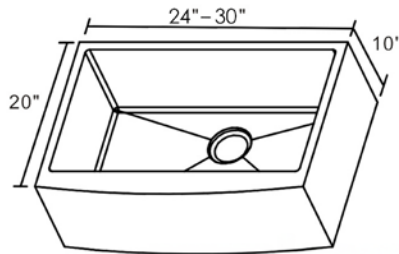

SINK GRIDS

| Item Number | Item Description | Size | LIST |
|-------------|---|------|--------|
| CDG-FA24 | Single Sink Grid for 24" Apron Front Sink | 24 | \$ 129 |
| CDG-FA30 | Single Sink Grid for 30" Apron Front Sink | 30 | \$ 139 |



ROLL MAT

| Item Number | Item Description | Size | LIST |
|-------------|------------------------------|------|-------|
| CRM-18 | Flat Roll Mat, 19" x 12 1/4" | 19 | \$ 89 |

Inventory levels are subject to change, check stock via Dealer Login on www.pinnaclesalesgroup.com

Sink Strainers

FEATURES

- Premium-Grade Material
- Mesh Design to Capture Large and Small Particles
- Hassle-Free Installation
- Universal Fit
- Easy to Clean
- 10-Year Warranty



STRAINERS

| Item Number | Item Description | LIST |
|-------------|--|--------|
| CST-100PC | Standard Strainer, Polished Chrome | \$ 69 |
| CST-100SS | Standard Strainer, Stainless Steel | \$ 69 |
| CST-200PC | Deep Strainer, Removable Basket, Polished Chrome | \$ 109 |
| CST-200BN | Deep Strainer, Removable Basket, Brushed Nickel | \$ 109 |

Disposal Flanges

FEATURES

- Premium-Grade Material
- Compatible with All Cameo® Waste Disposals
- Hassle-Free Installation
- Corrosion Resistant
- Seamless Design
- Easy to Clean
- Constructed to Withstand Daily Use
- 1-Year Warranty



DISPOSAL FLANGES

| Item Number | Item Description | LIST |
|-------------|---|--------|
| CDF-100PC | Standard Disposal Flange, Polished Chrome | \$ 69 |
| CDF-100BN | Standard Disposal Flange, Brushed Nickel | \$ 69 |
| CDF-200PC | Extended Disposal Flange, Removable Basket, Polished Chrome | \$ 109 |
| CDF-200BN | Extended Disposal Flange, Removable Basket, Brushed Nickel | \$ 109 |

Inventory levels are subject to change, check stock via Dealer Login on www.pinnaclesalesgroup.com

Soap Dispensers

FEATURES

- Smooth Pump Action for Easy Dispensing
- Slick Modern Design to Match Most Faucets and Sinks
- Multiple Finish Options to Match Hardware
- Compact Low Profile Spout Design for a Clean Countertop



SOAP DISPENSERS

| Item Number | Item Description | LIST |
|-------------|---------------------------------|-------|
| CSD-100CH | Soap Dispenser, Chrome | \$ 69 |
| CSD-100SS | Soap Dispenser, Stainless Steel | \$ 69 |
| CSD-100MB | Soap Dispenser, Matte Black | \$ 69 |

Filter Faucets



FILTER FAUCETS

| Item Number | Item Description | Faucet Height | Faucet Reach | LIST |
|-------------|--|---------------|--------------|--------|
| CFF-100SS | Filter Faucet, Square Spout, Stainless Steel | 10 37/64" | 6 19/64" | \$ 149 |
| CFF-300SS | Filter Faucet, Round Spout, Stainless Steel | 11 37/64" | 6 19/64" | \$ 149 |

ACCESSORIES

| Item Number | Item Description | LIST |
|---------------|--------------------------------------|-------|
| CKF-CARTRIDGE | Kitchen Faucet Cartridge Replacement | \$ 29 |

Inventory levels are subject to change, check stock via Dealer Login on www.pinnaclesalesgroup.com

Kitchen Faucets

FEATURES

- 304 Stainless Steel Construction
- 90° Forward Handle Operation for Full Range of Motion Against Wall Installations
- Pull-Down Swivel Spout on Select Models
- Hot and Cold Indicator on Base
- 2.2 GPM Flow Rate
- Ceramic Cartridge
- Transitional Design
- Stainless Steel Faucet Acceptable for Outdoor Use
- Single Handle Operation
- Easy Installation
- Pre-Installed Hot and Cold Water Lines Included
- Lifetime Warranty



PULL-DOWN KITCHEN FAUCETS



| Item Number | Item Description | Faucet Height | Faucet Reach | LIST |
|-------------|---|---------------|--------------|--------|
| CKF-200SS | Kitchen Faucet, Pull-Down, Stainless Steel* | 18 3/4" | 10" | \$ 449 |
| CKF-200MB | Kitchen Faucet, Pull-Down, Mate Black | 18 3/4" | 10" | \$ 449 |
| CKF-200CH | Kitchen Faucet, Pull-Down, Polished Chrome | 18 3/4" | 10" | \$ 449 |

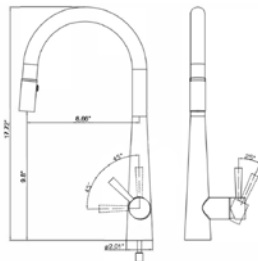

SQUARE SPOUT KITCHEN FAUCETS



| Item Number | Item Description | Faucet Height | Faucet Reach | LIST |
|-------------|---|---------------|--------------|--------|
| CKF-100SS | Kitchen Faucet, Square Spout, Stainless Steel | 15" | 12 1/2" | \$ 299 |

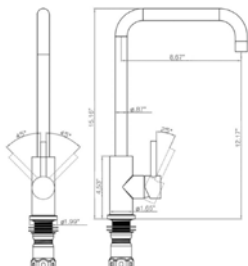

* Stainless Steel Faucet Acceptable for Outdoor Use

Inventory levels are subject to change, check stock via Dealer Login on www.pinnaclesalesgroup.com

Waste Disposers

FEATURES

- WhisperGrind Quiet Operation
- High-Powered Motor for Efficient Waste Grinding
- Stainless Steel Grinding Components
- Anti-Jamming System
- Easy Installation
- Continuous Feed Operation
- SpaceSaver Design Perfect for Compact Areas
- Attached Power Cord and Plug
- Removable Splash Guard
- 3-Bolt Mounting System



DISPOSERS

| Item Number | Item Description | LIST |
|-------------|---|--------|
| CWD-033S | Waste Disposer, 1/3 HP, Space Saver, 2400 RPM | \$ 189 |
| CWD-050S | Waste Disposer, 1/2 HP, Space Saver, 2600 RPM | \$ 219 |
| CWD-075S | Waste Disposer, 3/4 HP, Space Saver, 2700 RPM | \$ 339 |
| CWD-125S | Waste Disposer, 1 1/4 HP, Space Saver, 2800 RPM | \$ 429 |

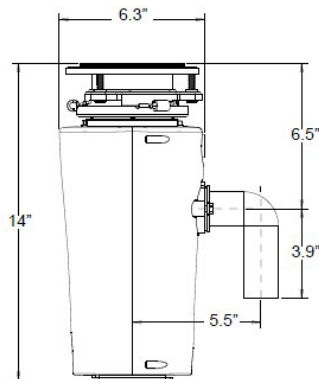

AIR SWITCHES



| Item Number | Item Description | LIST |
|-------------|--|--------|
| CAS-DCH | Dual Outlet Air Switch, Chrome (Includes Air Switch, Dual Outlet and Tube) | \$ 149 |
| CAS-DSS | Dual Outlet Air Switch, Stainless Steel (Includes Air Switch, Dual Outlet and Tube) | \$ 149 |
| CAS-DMB | Dual Outlet Air Switch, Mate Black (Includes Air Switch, Dual Outlet and Tube) | \$ 149 |

Cameo® Warranty

STAINLESS STEEL SINKS

Cameo® stainless steel sinks carry a lifetime warranty against manufacturing defects in material and workmanship. We are committed to providing you with products that meet the highest standards of quality and durability.

FAUCETS

All Cameo® faucets come with a lifetime warranty against manufacturing defects in material and workmanship. Please note that this warranty does not cover normal wear and tear of parts within the faucet.

WASTE DISPOSERS

Our waste disposers are designed for reliable performance and durability. The warranty coverage varies based on the horsepower of the disposer:

- 1/3 Horsepower: 5-year warranty
- 1/2 Horsepower: 6-year warranty
- 3/4 Horsepower: 10-year warranty
- 1 1/4 Horsepower: 12-year warranty

The Cameo® waste disposer warranty covers defects in material and workmanship, ensuring that the unit operates as intended. Additionally, all waste disposers carry a lifetime corrosion warranty. The stainless-steel grinding chamber parts (turntable, swivel impellers, and grind ring) make our disposers corrosion-proof, allowing us to offer a lifetime guarantee against failure due to corrosion. Any damage caused by misuse, lack of maintenance or improper installation will not be covered under the warranty.

ACCESSORIES

Cameo® accessories are covered by a 1-year warranty against manufacturing defects in material and workmanship. We stand behind the quality of our products and strive to ensure your satisfaction.

SINK STRAINERS

Our Cameo sink strainers come with a lifetime warranty against manufacturing defects in material and workmanship. Please note that this warranty does not cover normal wear and tear from daily use.



Terms and Conditions

Orders: All orders and any subsequent change orders must be submitted in writing and delivered to Pinnacle Express, Inc. dba Pinnacle Sales Group by mail, fax, EDI, website or e-mail. No telephone orders will be accepted. Special Order items are Non-Cancellable.

Prices: All prices are subject to change without notice and are exclusive of any sales or use taxes, shipping, delivery, special packaging, or handling charges that may apply to each customer or to each order.

Minimum Advertised Pricing: All sales are subject to Pinnacle Express, Inc. dba Pinnacle Sales Group or Manufacturer minimum advertised prices. Failure to comply with minimum advertised prices will result in cancellation of any agreement and violators will not be entitled to purchase further products.

Minimum Sale Price: All sales are subject to Pinnacle Express, Inc. dba Pinnacle Sales Group or Manufacturer minimum sale prices. Failure to comply with minimum sale prices will result in cancellation of any agreement and violators will not be entitled to purchase further products.

Freight and Handling: Pinnacle Express, Inc. dba Pinnacle Sales Group reserves the right to ship products by its choice of carrier. All shipments are F.O.B. from place of shipment, and risk of loss shall pass to the Buyer upon delivery to the carrier at the point of shipment. Additional charges may apply for special handling and packaging.

Deliveries: Pinnacle Express, Inc. dba Pinnacle Sales Group shall not be liable for failure to deliver or for delays in delivery or performance due to: (1) causes beyond its reasonable control; (2) acts of God, acts of Buyer, acts of civil or military authority, governmental allocations or controls, fires, strikes or other labor difficulties, riots or other civil disturbances, delays in its usual source of supply, delays in transportation; (3) any other commercial impracticability. In the event of such delay, the date of delivery or performance shall be extended for a period equal to the time lost by reason of the delay.

Claims: All claims for non-conforming delivery of Products must be made within thirty (30) days of receipt of shipment.

Damage or Loss: Any claim for damage or loss in shipment should be made to the carrier immediately by the customer. Products become the responsibility of the Buyer when accepted by the carrier in good condition from Pinnacle Express, Inc. dba Pinnacle Sales Group and we are not able to process shipping damage claims.

Returns: Only Items marked in this Price List as "Stock Item" are subject to return. All other items are considered Special Order Items and are NOT RETURNABLE. No Products may be returned without a Pinnacle Express, Inc. dba Pinnacle Sales Group Return Goods Authorization (RGA) Number issued prior to the return of Product. Any product returned without an RGA will be refused and returned to the sender. RGA's are valid for thirty (30) days only. All returns are subject to inspection before being approved for credit - products must be in salable condition to be considered for return or replacement. A 20% restocking charge will apply to all returns.

Payment: Unless otherwise noted, payment terms are Net Due on Receipt. Balances owed on invoices over 30 days old are subject to a 1.5% per month charge. Payments made by credit card are subject to a 3% processing fee. Each shipment or delivery shall be deemed to have been sold under a separate and or independent contract and payment thereof shall be made in accordance with the terms of this agreement and of the invoice rendered by Pinnacle Express, Inc. dba Pinnacle Sales Group Buyer agrees that title to the personal property described herein shall not vest in Buyer until paid in full. In the event of insolvency or the filing of bankruptcy by the Buyer, Buyer agrees to return all merchandise to Pinnacle Express, Inc. dba Pinnacle Sales Group

Warranties: Products distributed by Pinnacle Express, Inc. dba Pinnacle Sales Group are the products of reputable manufacturers sold under their respective brand or trade names. Pinnacle Express, Inc. dba Pinnacle Sales Group shall use its best efforts to obtain from each manufacturer, in accordance with the manufacturer's warranty or customary practice, the repair or replacement of products that may prove defective in material or workmanship. The foregoing shall constitute the exclusive remedy of the Buyer and the sole obligation of Pinnacle Express, Inc. dba Pinnacle Sales Group Except as to Title, THERE ARE NO WARRANTIES, EITHER WRITTEN, ORAL, IMPLIED, OR STATUTORY relating to the described products which shall extend beyond that described in this paragraph. NO WARRANTY OF MERCHANTABILITY OR OF FITNESS FOR PURPOSE SHALL APPLY.

Limitation of Liability: Pinnacle Express, Inc. dba Pinnacle Sales Group's liability on any claims for loss or damage arising out of this contract or from the performance or breach thereof or connected with the supplying of products hereunder, or its sale, resale, operation or use, whether based on warranty, contract, negligence or other grounds shall not exceed the price allowable for such products or parts thereof involved in the claim. Pinnacle Express, Inc. dba Pinnacle Sales Group shall not, under any circumstances, be liable for any labor charges unless agreed upon in advance and in writing by Pinnacle Express, Inc. dba Pinnacle Sales Group and the manufacturer of the products involved. Pinnacle Express, Inc. dba Pinnacle Sales Group shall not in any event be liable for special or consequential damages, including, but not limited to, loss of profits or revenue, loss of use of the product or any associated product, cost of capital, cost of substitute products, facilities or services, downtime costs, or claims of customers of the Buyer for such damages.

General: The possession of this Price List by anyone is not to be considered as an offer to sell any of the Products contained herein. This Price List supercedes all previous price lists or memorandums. Pinnacle Express, Inc. dba Pinnacle Sales Group's existing Trade Terms and Conditions remain in effect. The above Terms and Conditions shall be a part of all Orders accepted by Pinnacle Express, Inc. dba Pinnacle Sales Group and shall supercede any conflicting provisions of our customer's purchase orders. These terms and conditions are subject to change without notice.

Cameo



Pinnacle Sales Group, Inc.

P.O. Box 1836 • Dundee, FL 33838

Phone: 800-292-8374

www.pinnaclesalesgroup.com

CAM-PB-1025